

THE NEW XV COMPRESSOR  
SMALL IS THE NEW BIG



Up to 40% efficiency gain

Low height of 100 mm

Low noise of 32 dB(A)

Low weight of 4.8 kg

Up to 20 l extra storage volume in cooling cabinets

Broad dynamic range (1:4) and adaptable capacity

Reduces costs and sensitivity towards raw material

Eases process handling and stock

# EXTREMELY SMALL EXTREMELY EFFICIENT



Compressor size has always been an important topic in the household compressor business. It is quite simple. The larger the compressor is, the more it decreases the cooling volume in the cabinet.

Furthermore, large compressors have for many years kept preventing the business from serious innovation and the possibility to rethink household products.

Over time there have been several attempts to reach below the magic 100 mm height mark. It has now finally been achieved with the Secop XV compressor that manages to be exactly 100 mm high with rubber grommets.

Being so small is a major advantage. The XV compressor will make way for up to 20 l extra storage volume and it increases the total system efficiency to a whole new level.

Plus its physical size and extremely low weight, already challenges the conditions for what is possible – or not – in the future of the business.

What really makes the variable speed XV compressor so unique in the future of the household compressor business, is its extreme combination of small size with high performance. In the cabinet the XV compressor can be far more effective than the very best fixed speed compressors – even with much less use of copper.

In fact, it provides up to 40% efficiency gain compared to the highest efficient standard compressors, making it a superb environment-friendly choice. The efficiency gain is the result of the unique set-up, the external rotor technique and the fact that the XV compressor runs up to 100% of the time in the most effective area.



The XV compressor next to an NL compressor





Up to 40% efficiency gain

Low height of 100 mm

Low noise of 32 dB(A)

Low weight of 4.8 kg

Up to 20 l extra storage volume in cooling cabinets

Broad dynamic range (1:4) and adaptable capacity

Reduces costs and sensitivity towards raw material

Eases process handling and stock

# EXTREMELY SILENT EXTREMELY FLEXIBLE



Low noise has become an increasingly important parameter in modern household appliances, due to new ways of living and new end-user expectations.

Everybody wants the conveniences of a quality refrigerator. But no one wants to be bothered by the inconvenient noise it makes.

With a low noise of 32 dB(A), the Secop XV compressor is setting whole new standards, while still being able to increase total cabinet value.

Furthermore, the XV compressor is extremely flexible, due to its modular assembly design – both electronically and mechanical.

With its broad dynamic range (1:4) and adaptable capacity for various applications, it helps to cut down the need for different compressor solutions and leads to fewer variants.

The XV compressors adaptive and versatile qualities, means that it is configured to create smarter, better and more sustainable products, at a lower daily operating cost.





Up to 40% efficiency gain

Low height of 100 mm

Low noise of 32 dB(A)

Low weight of 4.8 kg

Up to 20 l extra storage volume in cooling cabinets

Broad dynamic range (1:4) and adaptable capacity

Reduces costs and sensitivity towards raw material

Eases process handling and stock

# BUILDING A NEW COOL FOR THE FUTURE



The XV compressor is built to introduce better and faster cooling in the most environment-friendly way. It signifies a rethinking of both the technology behind and the business upfront.

A big part of the XV compressors secret, is its unique external rotor motor that enables the use of much larger magnets, ensuring a superior compressor efficiency.

Another big part of the secret, is the know-how that goes into the assembly process. The key is the modular design of the XV compressor, combining the advantages of standardization with those of customization. On top of that, the compressor is uniquely assembled without any screws what so ever.

This new kind of construction also allows for a reduction in the use of the traditional and expensive copper material.

In short, the XV compressor not only ensures a remarkable reduction in weight and size and production costs. But also the modular assembly gives it a trendsetting quality while sustaining extreme flexibility.

In contrary to traditional fixed compressors, the XV also relies on variable speed. This rules out the constant stop-and-go-motion and minimizes the strain on the system.

Instead, the XV compressor runs almost full time. In doing so, the differential pressure between evaporator and the condenser is lower, leading to a more energy efficient condition for the compressor and a more balanced cooling temperature.



Reduced Vibration



Reduced Noise



Optimized Pressure



Broader Dynamic Range

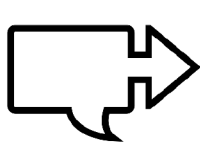

Faster Response



Up to 40%  
efficiency gain

Low height of  
100 mm

Low noise of  
32 dB(A)

Low weight of  
4.8 kg

Up to 20 l extra  
storage volume  
in cooling  
cabinets

Broad dynamic  
range (1:4)  
and adaptable  
capacity

Reduces costs  
and sensitivity  
towards raw  
material

Eases process  
handling and  
stock

NEVER HAS ANYTHING SO

small

PERFORMED SO **GREAT**



The new XV variable capacity compressor is the result of years of in-house research and development at Nidec GA Compressors. It really is the result of our unique ambition to set a new future standard for household compressors.

Intelligently combining an extremely small size with extremes in high performance, the Secop XV compressor pioneers the global demands for innovation, efficiency and sustainability.

The XV compressor represents a new beginning and rethinking of matters. Instead of being an improvement of our existing compressor platforms the small Secop XV compressor is based on a completely new system approach and new technology.



Actual size of the XV compressor (1:1 scale)

As an example, the XV compressor makes use of an external rotor motor and new innovative materials. Its simpler construction set-up add to both flexibility and efficiency and a considerable reduction in height, weight and noise.

Furthermore, the XV compressor is HST capable. This means it has a high starting torque and can start against a differential pressure. Also its wide voltage range (160-264 V at 50/60 Hz and 90-135 V at 50/60 Hz) means that it can operate in refrigerators and freezers in regions with an unstable voltage supply.

**In short, this small revolution:**

- Ensures you up to 40% efficiency gain compared to the highest efficient standard compressors
- Sets a new standard for low noise; 32 dB(A)
- Increases cooling volume in the cabinet and total system efficiency by having the low height of 100 mm
- Reduces costs and sensitivity towards raw material fluctuations due to an extreme low weight of 4.8 kg
- Eases process handling and stock
- Leads to fewer variants with a broad dynamic range

However big your challenges might appear the small Secop XV compressor is designed to provide the most intelligent and efficient performance.

Up to 40% efficiency gain

Low height of 100 mm

Low noise of 32 dB(A)

Low weight of 4.8 kg

Up to 20 l extra storage volume in cooling cabinets

Broad dynamic range (1:4) and adaptable capacity

Reduces costs and sensitivity towards raw material

Eases process handling and stock

# THE EVOLUTION OF REVOLUTION



The XV compressor is the result of a small team of in-house engineers dedicated to challenge the status quo.

Their aim, was to create a compressor that would break the 100 mm height mark for the first time and was as light as possible. They also wanted this small and light compressor to be more efficient than large fixed speed compressors.

As if that was not enough. The compressor should be both more profitable and more sustainable.

In order to do so, the team acknowledged that they had to forget everything they had learned and start all over again. Knowing that what they create will start a cool revolution.

The team developed a new technological platform called System Effective Coefficient Of Performance (SECOP) and combined with the external rotor motor technique, they had the basis for the XV compressor. Tests quickly showed that the impossible was not that impossible at all.

One of the leading household brands, BSH Group (BSH Bosch und Siemens Hausgeräte GmbH) has joined the development of the intelligent XV compressor closely.

With this new series, BSH is looking forward to setting new standards itself and also have much greater flexibility in production, due to its adaptable capacity for various applications.

In that respect, the XV is already on the way to become a vital part of a new generation of innovative home appliance solutions at BSH Group and other leading household brands.

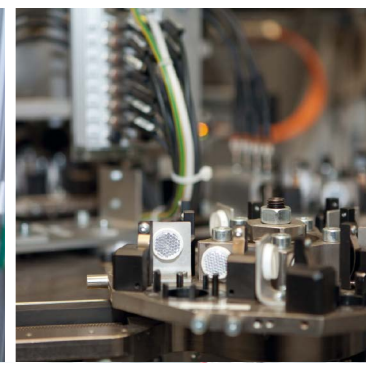
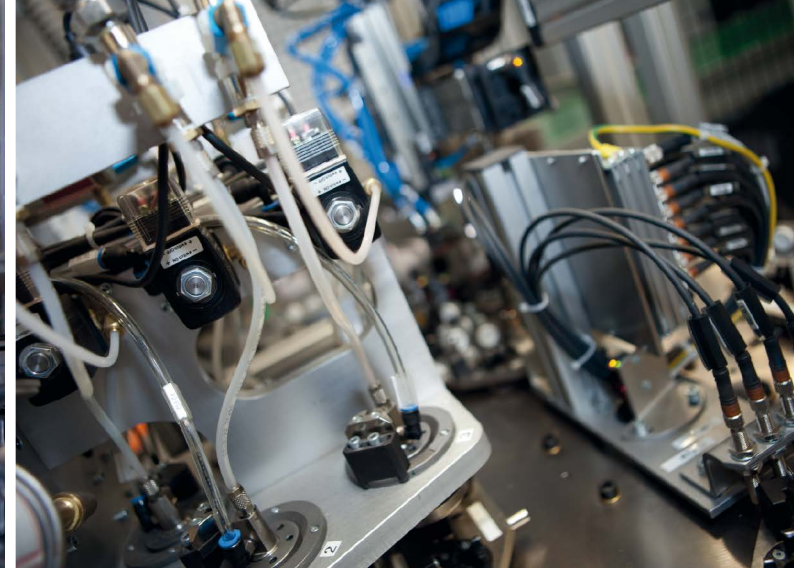

Up to 40% efficiency gain

Low height of 100 mm

Low noise of 32 dB(A)

Low weight of 4.8 kg

Up to 20 l extra storage volume in cooling cabinets

Broad dynamic range (1:4) and adaptable capacity

Reduces costs and sensitivity towards raw material

Eases process handling and stock

# SECOP XV COMPRESSOR A NEW STANDARD FOR COOL SAVINGS



**Danish Technological Institute has together with EUDP and the producer Vestfrost Solutions made comprehensive energy tests of commercial wine coolers. Results show that the variable speed Secop XV5.0KX compressor ensures a 47% overall energy savings compared to wine coolers with fixed speed compressors.**

Design and usability are important matters in the light commercial market, but above all rates costefficiency. The refrigerators, freezers and coolers are always in use. This is why improved energy efficiency along with increasing environmental standards is so essential to the business.

Together with Danish Technological Institute and EUDP – a program that furthers new energy-friendly technologies – the Danish producer Vestfrost Solutions made numerous tests, both in laboratories and 'real life' in order to ensure that their new wine coolers also would set a new standard for energy savings.

## **WINE COOLER + XV COMPRESSOR WITH VARIABLE SPEED = UP TO OVERALL 47% ENERGY SAVINGS**

The criteria included a compressor, that could combine high performance and low energy consumption with temperature precision and low noise. Tests demonstrated that the Secop XV5.0KX compressor was a very good match.

In contrast to fixed compressors the XV5.0KX is able to adjust the supplied cooling capacity of the compressor to the needed cooling capacity of the cabinet by operating at different speeds.

This rules out the constant stop-and-go motion and leads to a more balanced cooling temperature and reduces energy consumption considerably. Results showed the Secop XV5.0KX compressor managed the same high performance as the fixed compressors but used 36% less energy.

## **BEST IN CLASS + BEST IN FIT**

The XV compressor made the Vestfrost Solutions wine cooler take a best-in-class leap from energy efficiency class B to energy efficiency class A+ and provided simultaneously improvements on noise levels – an instrumental feature when choosing wine coolers.

Furthermore, the compressor was able to demonstrate great flexibility. Due to its extremely small size and weight, it only took minor adjustments to make the Secop compressor fit in with the preexisting cabinet.

With the XV5.0KX, it is possible to reduce energy consumption without big changes to appliance design.

## **A NEW COOL FOR WINE COOLERS**

Vestfrost Solutions has been pleased with the outcome and so has the different end users who already have had the chance to try out the "upgraded" wine coolers.

They mention the new cooling qualities as something to look out for and naturally the prospect of saving both energy and total costs.



Up to 40% efficiency gain

Low height of 100 mm

Low noise of 32 dB(A)

Low weight of 4.8 kg

Up to 20 l extra storage volume in cooling cabinets

Broad dynamic range (1:4) and adaptable capacity

Reduces costs and sensitivity towards raw material

Eases process handling and stock

## TECHNICAL DATA



Nidec GA Compressors' revolutionary X-Series compressor range is entirely new and relies on new compressor technology that Nidec GA Compressors has developed in-house.

The completely new platform not only offers the highest system efficiency, but is also with its dimensions challenging the standards for compressor size in the future

The innovative design from a production point of view is a pioneer which has all-welded parts that are assembled by the latest robotic automated systems, ensuring a trendsetting quality level.

Research and development is a high priority at Nidec GA Compressors and we continue to deliver innovative, energy saving products to OEMs and end users alike

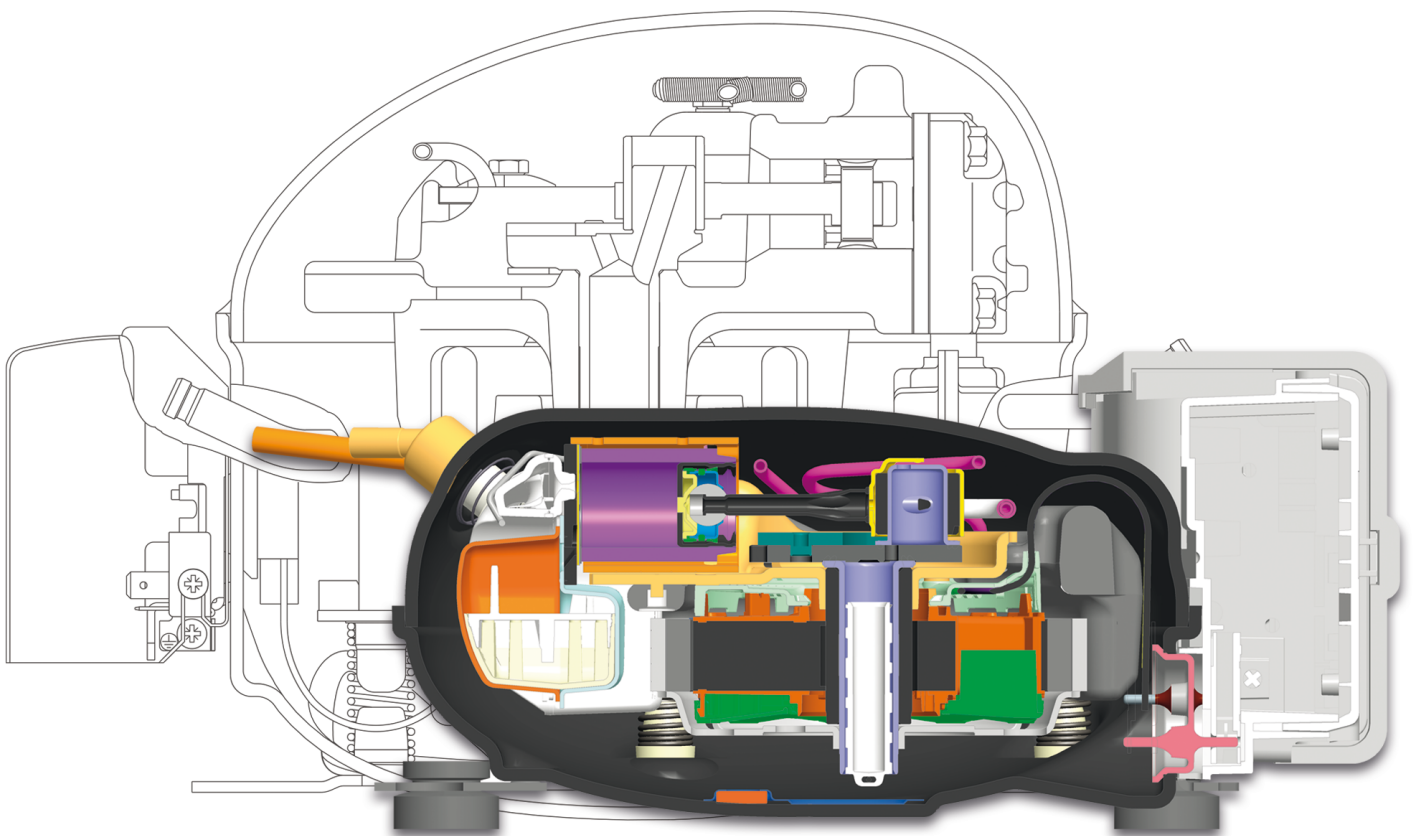

The XV compressor compared to an NL compressor

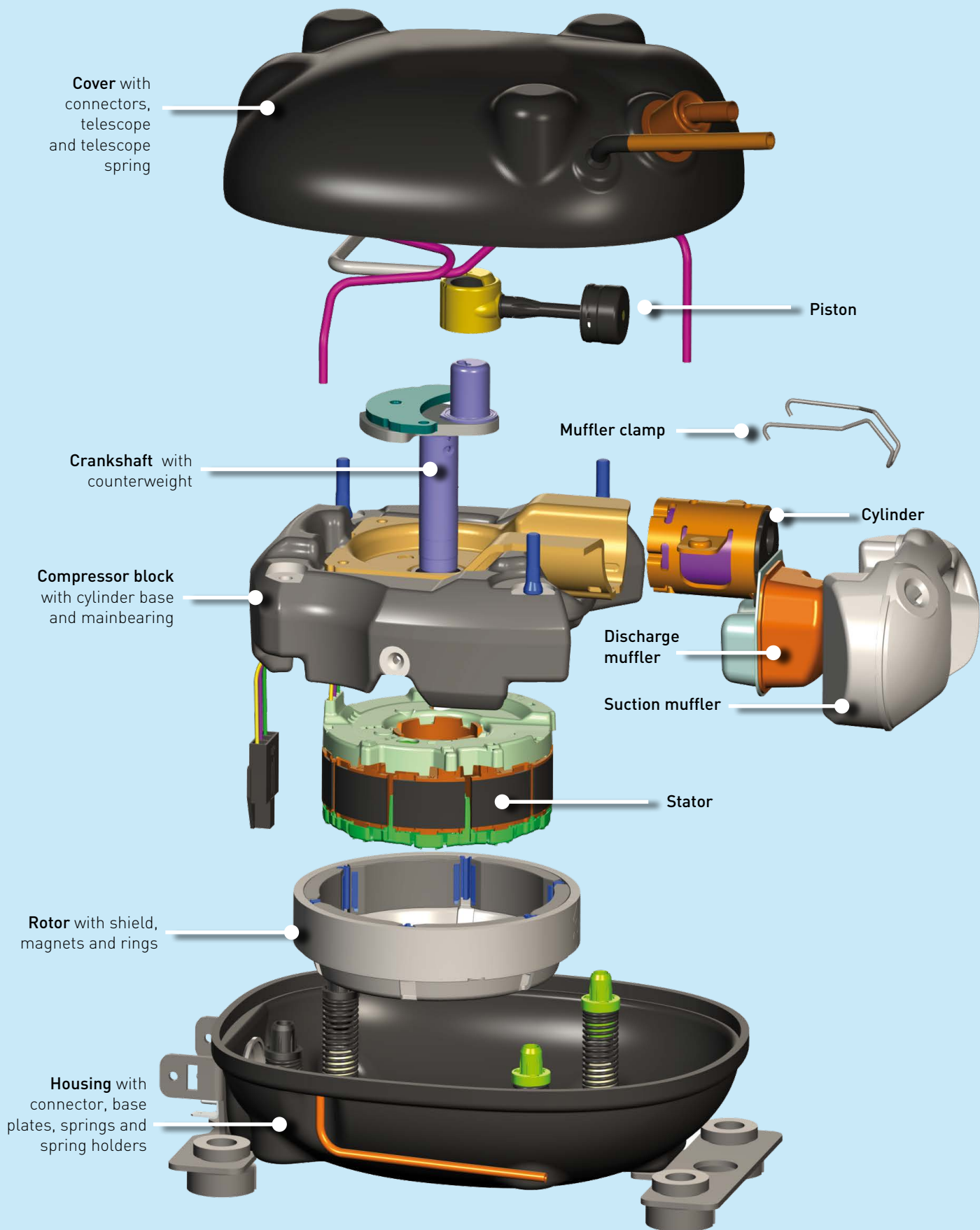

**XV features**

- eXtremely small
- eXtremely light
- eXtremely efficient
- eXtremely flexible

**... your benefits**

- Additional storage volume for refrigerators
- Less weight, easier handling, lower transport costs
- Increased system efficiency
- Adaptable capacity for various applications

# XV-KX COMPRESSORS, 220-240 V, 50/60 Hz

General (code numbers)	XV5.0KX	XV7.2KX	XV8.0KX
Compressor, without electronic unit (4.8 kg)	108H5013	108H7211	108H7712
Electronic unit (attached) - XV-AEO/Freq.* Inputs: Thermostat, frequency signal, Modbus	105N5022	105N5022	105N5022
Electronic unit (detached) - XV-Frequency Input: Frequency signal	105N5052	105N5052	105N5052
Electronic unit (attached, PFC) - XV-AEO/Freq. Inputs: Thermostat, frequency signal, Modbus	105N5320	105N5320	105N5320
Approvals	Electronic unit with PFC = Power Factor Correction according to EN 61000-3-2:2014 EN 60335-2-34 with Annex AA (VDE), GB 4706.17 (CCC/CQC)		

\* AEO algorithm: In AEO (Adaptive Energy Optimizing) speed mode the XV compressor will always adapt its speed to the actual cooling demand. The AEO function is very suitable for tropical applications, systems with huge load variations and applications where energy is an important issue. Furthermore it can be an advantage to use it when it is difficult to determine at what speed the compressor should run.

Application		LBP/MBP	LBP	LBP
Application				
Evaporating temperature	°C	-35 to 5	-35 to 0 (-5/-10)	-35 to 0 (-5/-10)
Voltage range / frequency	V/Hz	160 - 264 / 50/60	160 - 264 / 50/60	160 - 264 / 50/60
Speed range	rpm		1000 - 4000	

**Remarks:** HST capable (high starting torque, start against differential pressure).  
All measured performance data include losses caused by electronic unit.

Performance data ASHRAE LBP (220 V, 50/60 Hz • static cooling) @ -23.3 °C evaporating temperature													
Speed	rpm	1000	1200	1600	4000	1000	1200	1600	4000	1000	1200	1600	4000
Cooling capacity	W	22.0	27.2	37.5	92.9	39.1	47.1	63.0	145	43.6	54.1	75.1	165
Power consumption	W	13.2	15.9	21.5	56.1	21.7	26.1	34.8	85.9	24.0	29.3	39.9	96.0
COP	W/W	1.67	1.71	1.75	1.66	1.80	1.81	1.81	1.69	1.82	1.85	1.88	1.72

Performance data Optimization Point (220 V, 50/60 Hz • static cooling • pc = 35 °C / Tliq = 35 °C / Tsuc = 32 °C) @ -25 °C evap. temp.													
Speed	rpm	1000	1200	1600	4000	1000	1200	1600	4000	1000	1200	1600	4000
Cooling capacity	W	27.8	34.1	46.0	106	42.1	50.5	67.4	150	44.7	54.8	75.1	164
Power consumption	W	12.9	16.0	21.7	55.5	19.0	22.9	30.9	76.9	20.0	24.6	33.8	85.6
COP	W/W	2.15	2.14	2.12	1.90	2.22	2.20	2.18	1.95	2.23	2.23	2.22	1.92

Dimensions			
Height	mm	A	97
		B	91
Suction connector	location/I.D. mm   angle material   seal	C	6.2   12° Copper   Rubber plug
		D	6.0   7° Copper   Rubber plug
Discharge connector	location/O.D. mm   angle material   seal	E	3.2   30° Cu-plated steel   Rubber plug
		Connector tolerance	I.D. mm 6.2 ±0.09. 6.0 ±0.1. 3.2 ±0.05

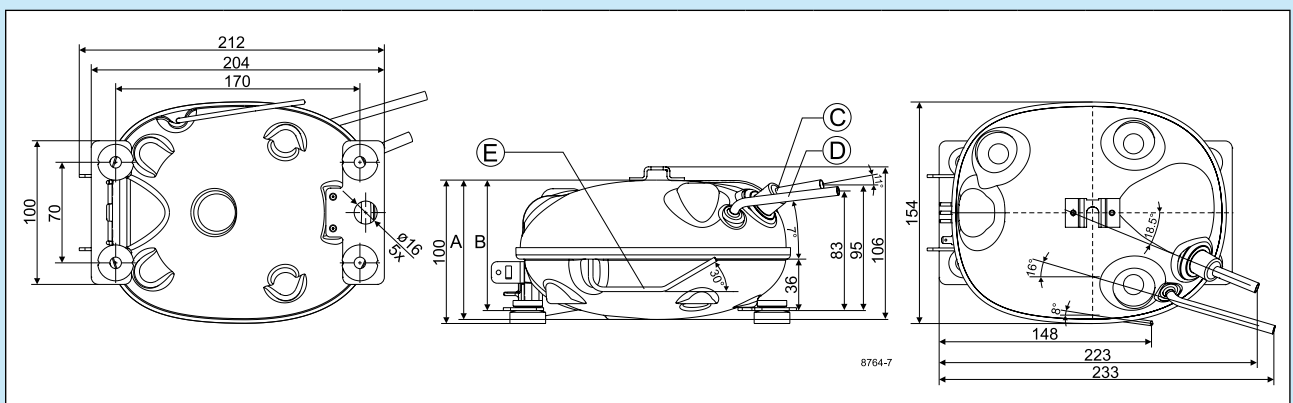

# XV-KX COMPRESSORS, 100-127 V, 50/60 Hz

General (code numbers)	XV5.0KX	XV7.2KX	XV8.0KX
Compressor, without electronic unit (10.6 lbs.)	108H5014	108H7214	108H7714
Electronic unit (attached) - XV-AEO/Freq. *	105N5312	105N5312	105N5312
Inputs: Thermostat, frequency signal, Modbus			
Electronic unit (detached) - XV-Frequency	105N5150	105N5150	105N5150
Input: Frequency signal			
Approvals	UL 60335-2-34		

\* AEO algorithm: In AEO (Adaptive Energy Optimizing) speed mode the XV compressor will always adapt its speed to the actual cooling demand. The AEO function is very suitable for tropical applications, systems with huge load variations and applications where energy is an important issue. Furthermore it can be an advantage to use it when it is difficult to determine at what speed the compressor should run.

Application			
Application		LBP/MBP	LBP
Evaporating temperature	°F	-31 to 45 [40/32]	-31 to 32 [20/14]
Voltage range / frequency	V/Hz	90 - 135 / 50/60	90 - 135 / 50/60
Speed range	rpm	1000 - 4000	

**Remarks:** HST capable (high starting torque, start against differential pressure).  
All measured performance data include losses caused by electronic unit.

Performance data ASHRAE LBP (115 V, 50/60 Hz • static cooling) @ -10 °F evaporating temperature													
Speed	rpm	1000	1200	1600	4000	1000	1200	1600	4000	1000	1200	1600	4000
Cooling capacity	BTU/h	75	93	128	317	133	161	214	495	149	185	252	563
Power consumption	W	12.6	15.6	21.4	52.6	21.6	26.1	34.9	87.7	23.9	29.2	39.5	98.6
EER	BTU/Wh	5.95	5.95	5.98	6.03	6.16	6.16	6.13	5.64	6.23	6.32	6.39	5.72

Performance data AHAM (115 V, 50/60 Hz • static cooling • pc = 105 °F / Tliq = 90 °F / Tsuc = 90 °F) @ -10 °F evaporating temperature													
Speed	rpm	1000	1200	1600	4000	1000	1200	1600	4000	1000	1200	1600	4000
Cooling capacity	BTU/h	102	124	165	377	157	189	251	567	168	206	278	615
Power consumption	W	13.0	16.2	22.0	51.1	20.6	24.9	33.6	84.3	22.0	26.8	36.2	90.9
EER	BTU/Wh	7.82	7.65	7.50	7.37	7.66	7.60	7.49	6.73	7.64	7.68	7.67	6.77

Dimensions			
Height	inch	A	4.17
		B	3.98
Suction connector	location/I.D. inch   angle material   seal	C	0.202-0.205   11° Copper   Rubber plug
		D	0.202-0.205   15° Copper   Rubber plug
Process connector	location/O.D. inch   angle material   seal	E	0.202-0.205   0° Copper   Rubber plug

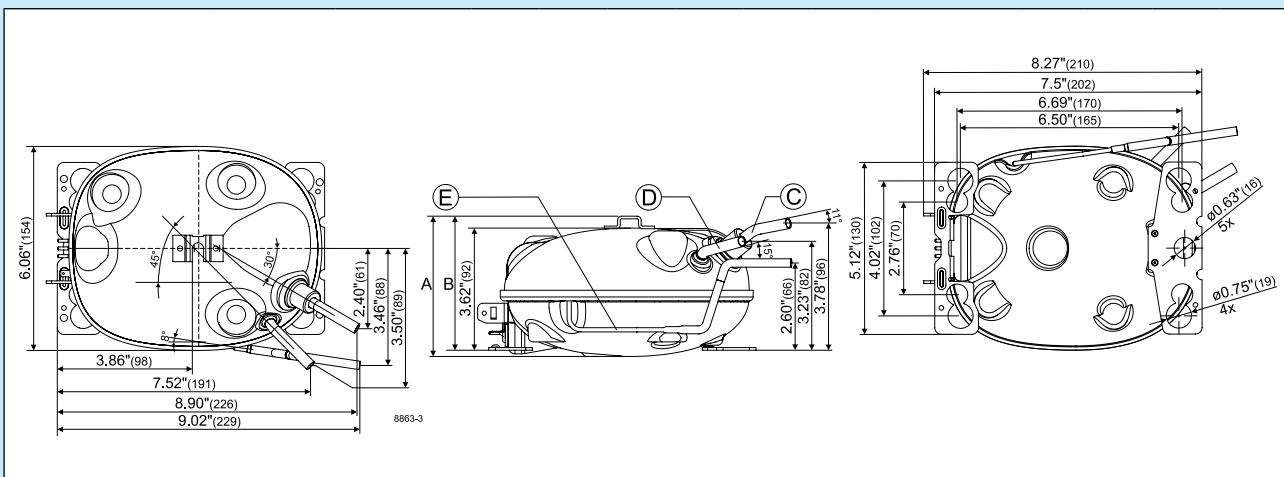

Electronic unit XV-AEO/Freq. 105N5022 (160-264 V, 50/60 Hz) - attached

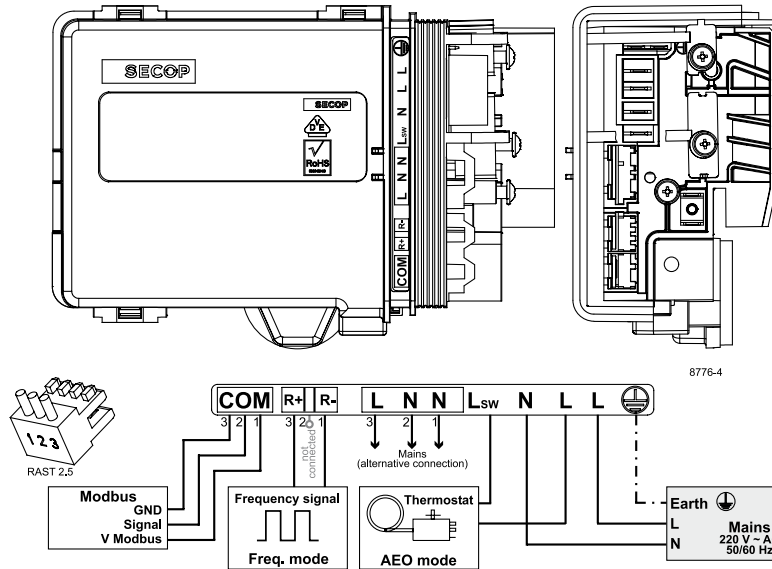

Electronic unit XV-Frequency 105N5052 (160-264 V, 50/60 Hz & 105N5150 (100-127 V, 50/60 Hz) - detached

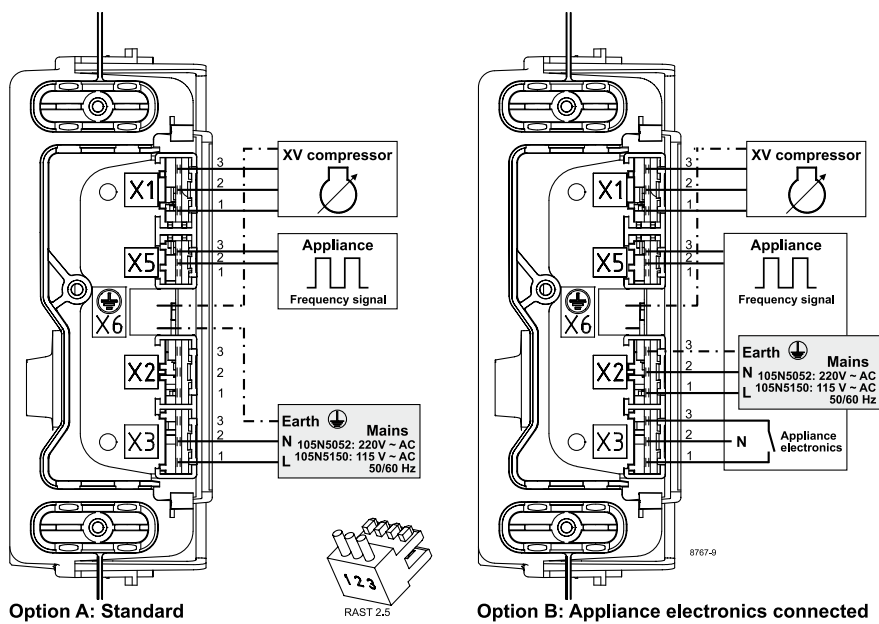

Electronic unit **XV-AEO/Freq.** 105N5022 with PFC (160-264 V, 50/60 Hz) - attached

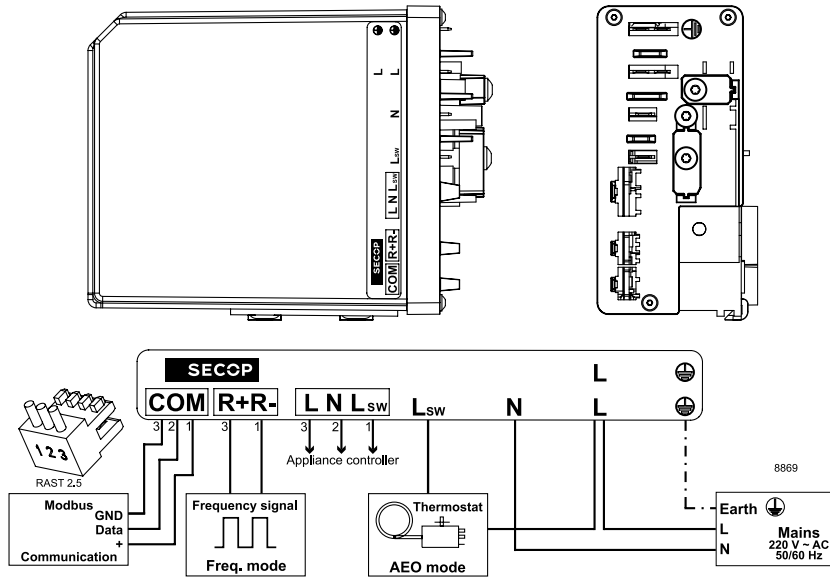

Electronic unit **XV-AEO/Freq.** 105N5312 (100-127 V, 50/60 Hz) - attached

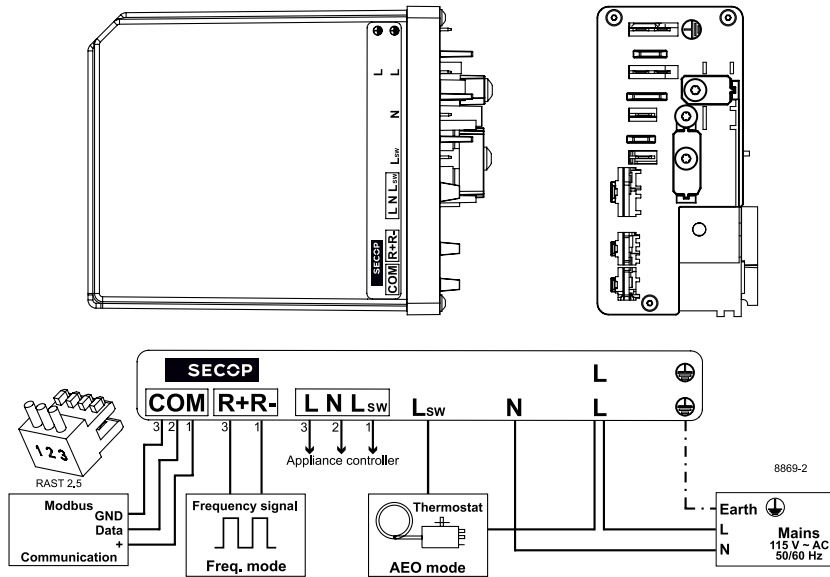

Electronic unit **XV-AEO/Freq.** 105N5310 (100-127 V, 50/60 Hz) - attached, under development

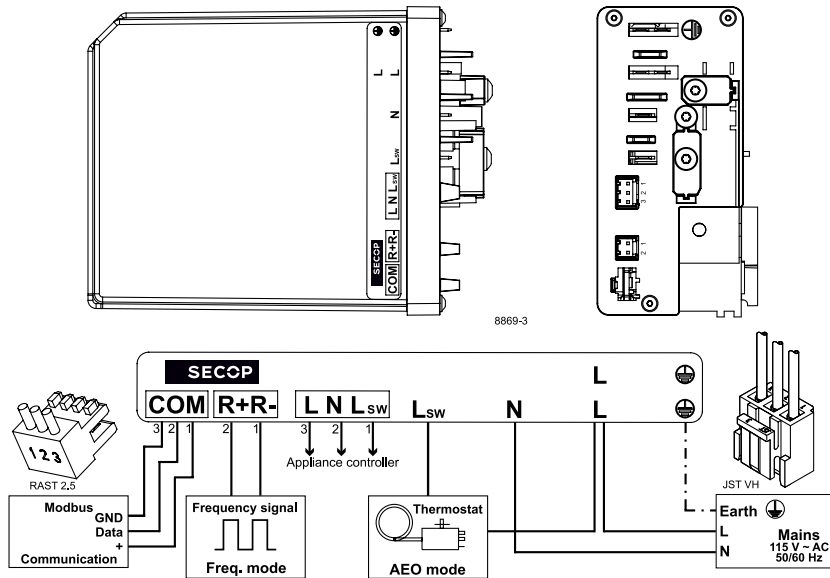



## LEADING TECHNOLOGY THE RESPONSIBLE WAY



At Nidec GA Compressors, the development of leading compressor technologies always goes hand in hand with social and environmental responsibility.

We think it is the least we can do, helping our customers to meet regulations and build a better world.

This means all Secop compressors are designed to save energy and reduce emissions in customer applications all over the world.

It also means that we carry out environmental manufacturing practices wherever we operate.

It means we are a participant of the Global Compact, an initiative of the United Nations for businesses that are committed to aligning their operations and strategies with ten universally accepted principles in the areas of human rights, labour, environment, and anti-corruption.

And it means that when you choose a Secop compressor, you're opting for high-performing solutions that cool with a conscience – now and in the future.

**Nidec Global Appliance Germany GmbH** · Mads-Clausen-Str. 7 · 24939 Flensburg · Germany · Tel: +49 461 4941 0 · [www.secop.com](http://www.secop.com)

Nidec GA Compressors accepts no responsibility for possible errors in catalogs, brochures, and other printed material. Nidec GA Compressors reserves the right to alter its products without notice. This also applies to products already on order provided that such alterations can be made without subsequent changes being necessary to specifications already agreed. All trademarks in this material are the property of the respective companies. Secop and the Secop logotype are trademarks of Nidec Global Appliance Germany GmbH. All rights reserved.